

VISION OUTSIDE CLASSIC LATCH POINT



The system is mounted outside the sealing area. When the swing handle is turned to close, the upper flat rod is moving upwards and the lower rod downwards.

Control mechanism with flat rod and rod guide ordered separately.



MATERIAL

Latch point: Zinc die cast, zinc plated or special surface treatment*

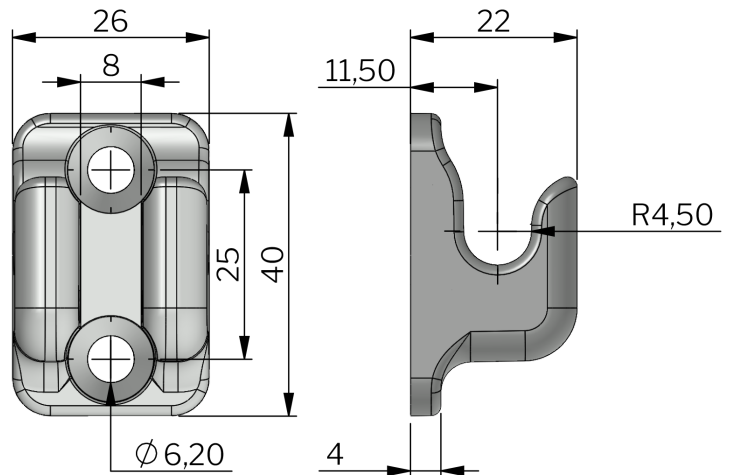

P/N	Material
13110201	Zinc die cast, zinc plated
13140201	Zinc with surface treatment "Highlander"