

KLIMA-FLEX LATCH HINGE GEN2



The patented Klima-flex latch hinge is specifically for insulated and pressurized doors. The hinge creates 6 mm compression and allows you to open the doors 180° in either direction, or to remove the door completely.

The safe two-stage opening process allows the cabinet to depressurize before it is fully opened. A distinct click delivers tactile feedback on whether the door is open or closed. For extra stability, mounting bracket is available.

Meets the requirements for sealing level L1 according to DIN EN 1886.

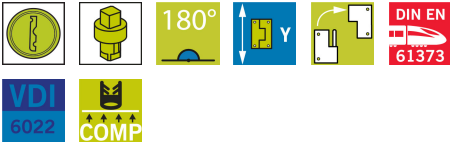

MATERIAL

Cylinder: Zinc die cast, stainless steel 304 cap and dust shutter

Door part: Glass fibre reinforced polyamide (PA6GF30)

Frame part: Zinc die cast, black powder coated

Handle: Glass fibre reinforced polyamide (PA6GF30)

Insert: Zinc die cast, black texture powder coated

Latching cam: Zinc die cast, black powder coated

Mounting bracket: Zinc die cast, zinc plated
Pin: Stainless steel 304

RELATED PRODUCTS

Hinges: 3-156

Similar products: 2-317cd

Keys: 2-372, 2-380, 2-370

Use the Index Code at industrilas.com

TECHNICAL INFORMATION

Standards: DIN EN 61373, VDI 6022

Cylinder information: Supplied with two keys

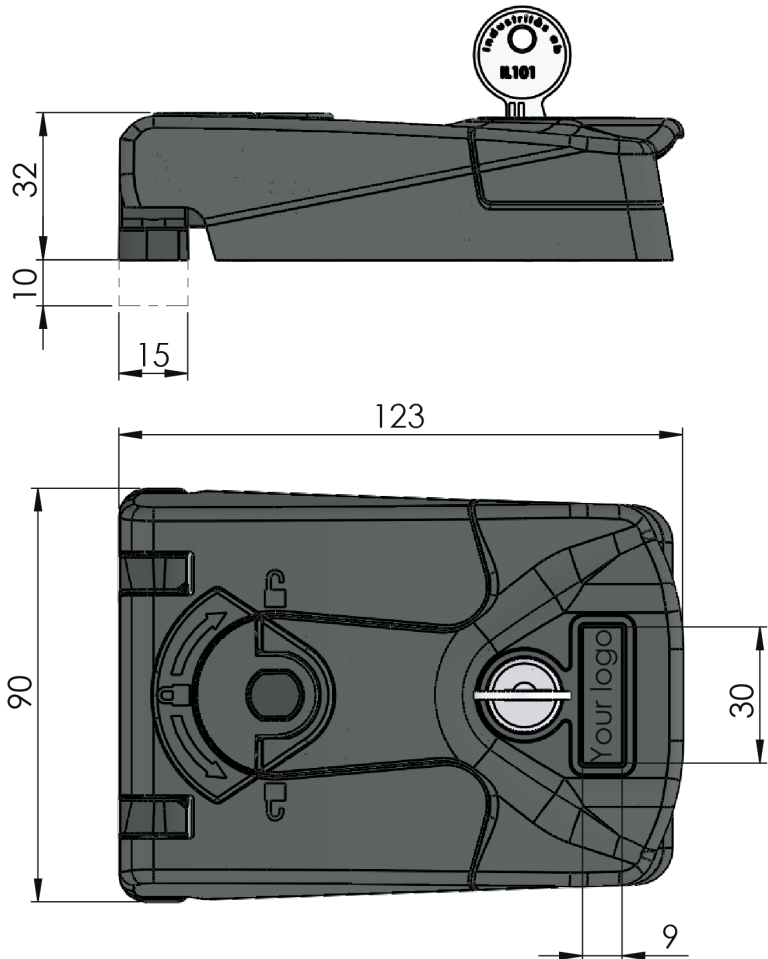

Make your selections in each column to create your article number (AAAA-BBCCDD-EE)

AAAA Type	BB Type	CC Frame part offset	DD Insert	EE Description
2651 Klima-flex	44 Latching hinge GEN2	00 0 mm	00 Non-locking	00 Without mounting plate
		10 10 mm	03 Square 7	01 With mounting plate
			05 Square 8	
			14 Triangle 7	
			15 Triangle 8	
			22 Double Bit 3	
			24 Double Bit 5	
			32 Hexagon 11	
			34 Recessed hexagon 8	
			35 Recessed hexagon 10	
			36 Recessed hex 8 / 3 mm pin	
			80 Keyed alike IL101	

