

# VISION SWING HANDLE HIGHLANDER TOOL OPERATED

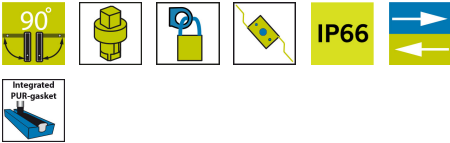

Low profile swing handle for control mechanism with insert. Vision Highlander design withstands 1000 hours in salt fog and 45 Nm torque. Available in turn-to-latch version where the door is locked by turning the key and push-to-latch version where the spring-loaded cam latches when the handle is pushed in. The handle is padlockable and the spring-loaded padlock loop retracts when the handle is released. Suitable for doors with 0.8–3.5 mm thickness.



## MATERIAL

**Dish:** Zinc die cast, black coated or fibre glass reinforced polyamide (PA6GF30)  
**Handle:** Zinc die cast, black coated or fibre glass reinforced polyamide (PA6GF30)  
**Insert:** Stainless steel 304  
**Padlock loop:** Stainless steel 304  
**Pivot shaft:** Zinc die cast, special surface treatment (passes 30 day salt-spray test according to ISO 9227, equivalent to ASTM B 117.)

## RELATED PRODUCTS

**Rod latch systems:** 1-008.04, 1-008.21, 1-008.25, 1-008.07  
**Keys:** 2-372, 2-370  
**Other materials:** 6-010  
**Similar products:** 1-004.13  
 Use the Index Code at [industrilas.com](http://industrilas.com)

## TECHNICAL INFORMATION

**Cutout:** Version C  
**Standards:** IP66, NEMA 4

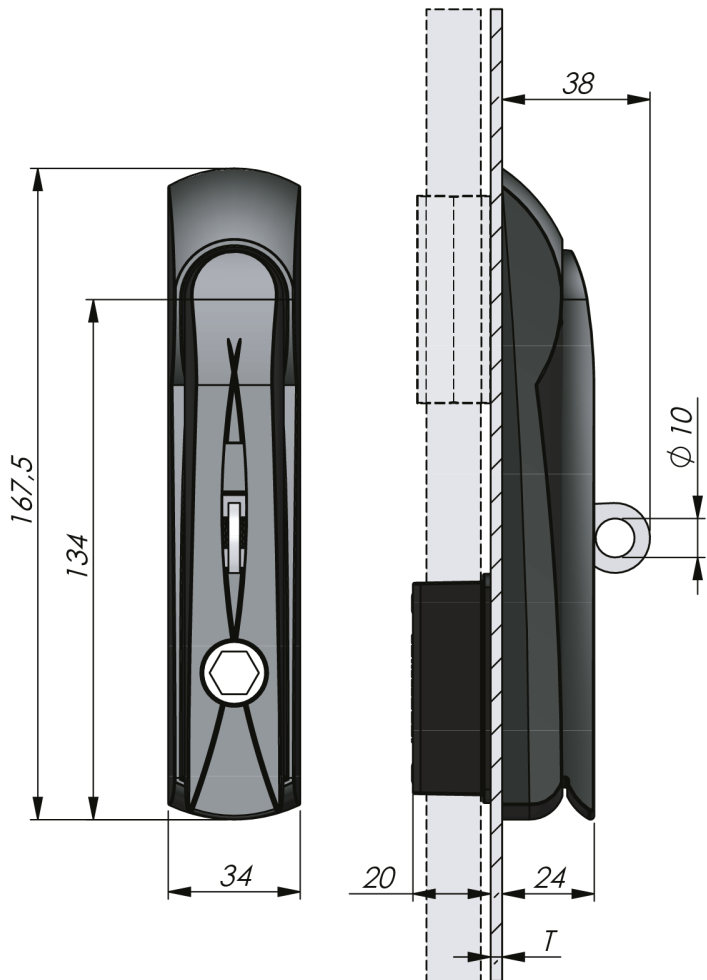

**Make your selections in each column to create your article number (AAAAAAABC-DDDDE)**

AAAAAAA	Material	B Door thickness T	C PDL	DDDD	Insert	E Model
1216117	Handle zinc / dish PA6	1 0,8 - 1,5 mm	0 No	9001	Hexagon 11	0 Turn-to-latch
1216417	Handle zinc / dish zinc	2 1,6 - 2,5 mm	1 Yes	9047	Recessed hex 8 / 3 mm pin	1 Push-to-latch
		3 2,6 - 3,5 mm				

PDL = Spring loaded padlock loop retracts when handle is released.

Version C

