

VISION™ SWING HANDLE STANDARD TOOL OPERATED

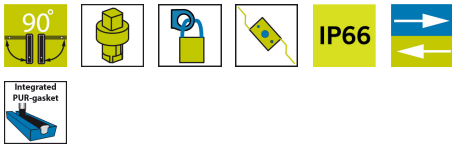

Low profile swing handle with insert for control mechanism. Available in turn-to-latch version where the door is locked by turning the key and push-to-latch version where the spring-loaded cam latches when the handle is pushed in.



MATERIAL

Dish: Zinc die cast, black coated or fibre glass reinforced polyamide (PA6GF30)
Handle: Zinc die cast, black coated or fibre glass reinforced polyamide (PA6GF30)
Insert: Zinc die cast, chrome plated
Padlock loop: Stainless steel 304
Pivot shaft: Zinc die cast, zinc plated

RELATED PRODUCTS

Rod latch systems: 1-008.04, 1-008.21, 1-008.25, 1-008.07
Keys: 2-372, 2-370
Other materials: 6-010
Similar products: 1-002.13
 Use the Index Code at industrilas.com

TECHNICAL INFORMATION

Cutout: Version C
Standards: IP65, NEMA 4

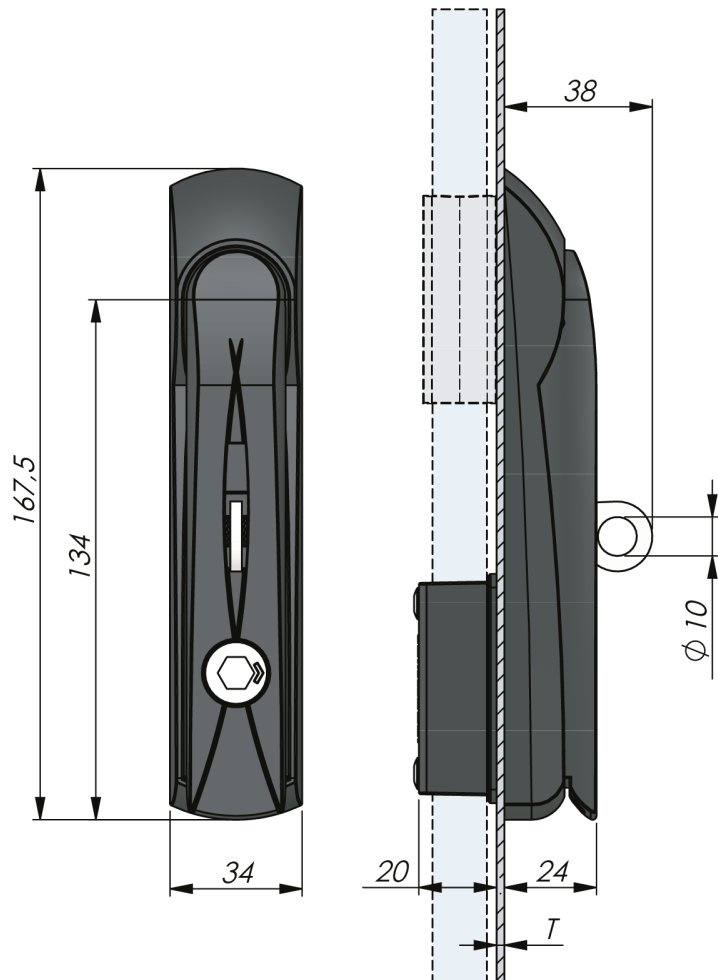

Make your selections in each column to create your article number (AAAAAAABC-DDDDE)

AAAAAAA	Material	B Door thickness T	C PDL	DDDD	Insert	E Model
1216118	Handle zinc / dish PA6	1 0,8 - 1,5 mm	0 No	1301	Hexagon 11	0 Turn-to-latch
1216418	Handle zinc / dish zinc	2 1,6 - 2,5 mm	1 Yes	1308	Square 7	1 Push-to-latch
1250118	Handle PA6 / dish PA6	3 2,6 - 3,5 mm		1309	Square 8	
				1312	Triangular 7	
				1313	Triangular 8	
				1316	Double Bit 3	
				1317	Double Bit 5	
				1320	Slotted	
				1347	Insex 8 / 3 mm pin	

PDL = Spring loaded padlock loop retracts when handle is released.

Version C

