

HVAC LIGHT FOR INSPECTION WINDOW



IP45

Practical, powerful lamp, very suitable for retrofitting. The lighting unit can be used with all square Industrilas inspection windows at 5-252 (PN 506002-XX).

It consists of a stable plastic housing with an adapted TPE seal. Sealed IP45 (with button facing downwards). The circuit board is equipped with 6 white LEDs, which are operated with 2 AAA batteries via an integrated battery compartment. The high quality batteries are included.

The pressure switch lights up the LEDs for 30 seconds. This prevents the batteries from being drained unintentionally. Alternatively, an external power supply can be soldered onto the board. The power supply should be 5V 500mA. A cable passage is provided on the seal.

The lighting unit can be mounted in four positions on the viewing window. Longer screws are included in the scope of delivery for the different door thicknesses. They can be mounted with a TORX 20 tool.

MATERIAL

Gaskets: TPE
Housing: PC-ABS
Screw: Stainless steel

RELATED PRODUCTS

Needed components for a complete system:
 5-252
 Use the Index Code at industrilas.com

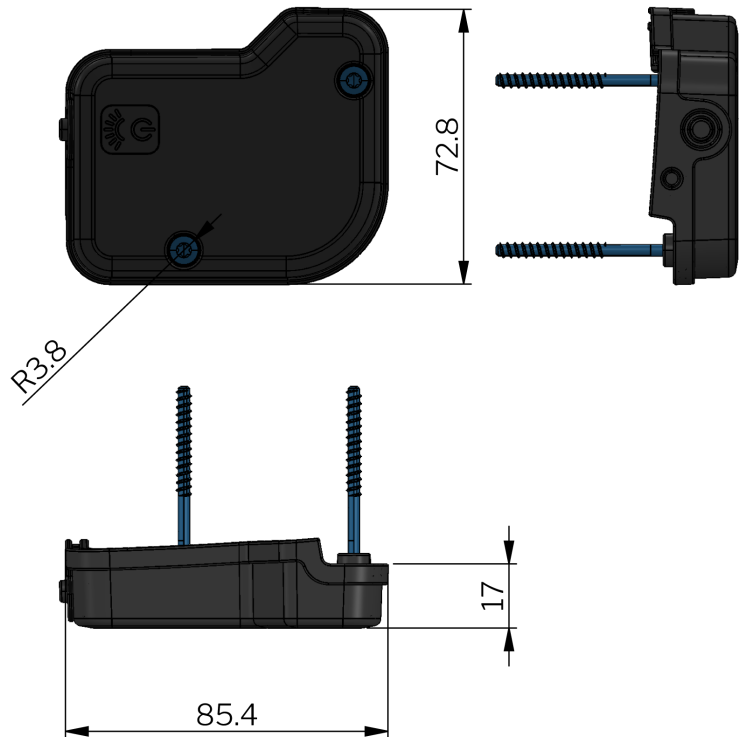

celator

P/N

5071-5030115-000

Please note

- Tightening torque of the screws: 1.5 - 2 Nm with TORX 20.
- The LEDs switch off automatically after 30 seconds.
- The alternative power supply should have a voltage of 5V 500mA DC.
- The light intensity is 100 lumens.
- IP45 (with button facing downwards)