

# VISION FLAT ROD 2100 MM



2100 mm flat rod with preassembled control mechanism. Can be used for Vision Outside (Index Code 1-008.05) and Vision Inside (Index Code 1-008.13).

Possible to mount latch points every 100 mm.

## MATERIAL

**Control mechanism:** Zinc die cast, zinc plated, special surface treatment (passes 30 day salt-spray test according to ISO 9227, equivalent to ASTM B 117) or glass fibre reinforced polyamide (PA6GF30)

**Rod:** Steel, zinc plated or stainless steel 316

## RELATED PRODUCTS

**Rod latch systems:** 1-008.05, 1-008.13

Use the Index Code at [industrilas.com](http://industrilas.com)

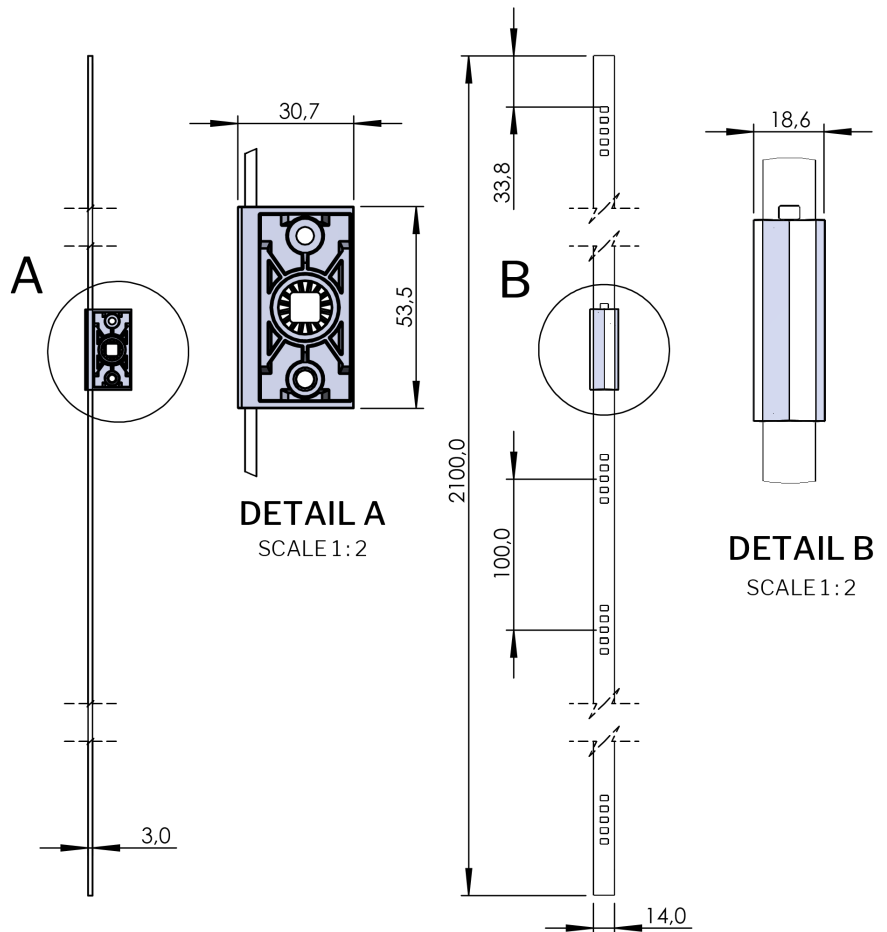

P/N	Material rod	Material control mechanism
1321-1100-2100	Steel, zinc plated	Zinc die cast, zinc plated
1350-1100-2100	Steel, zinc plated	Glass fibre reinforced polyamide (PA6GF30)
1390-1100-2100	Stainless steel 316	Zinc die cast with surface treatment "Highlander"

