

# INSPECTION WINDOW CIRCULAR



Circular inspection window in transparent, impact-resistant polycarbonate. Intended for HVAC-applications using insulated or double-skinned doors. The window is equipped with an integrated gasket and is suitable for units with positive or negative pressure. The window is delivered in two halves that are assembled in the door with a  $\varnothing 182$  mm hole. Simple mounting by using the included bolts and nuts.

Diameter for circular placement of mounting holes is 195 mm.



## MATERIAL

- Nut:** Stainless steel 304
- Screw:** Stainless steel 304
- Sealing:** Foamed PUR-gasket (polyurethane)
- Window:** Polycarbonate/Macrolone 6557, crystal clear and impact resistant

## RELATED PRODUCTS

**Similar products:** 5-252  
Use the Index Code at [industrilas.com](http://industrilas.com)

## TECHNICAL INFORMATION

Customer logo may be included upon request.  
Door thickness tolerance:  $\pm 2$  mm.

**Standards:** VDI 6022

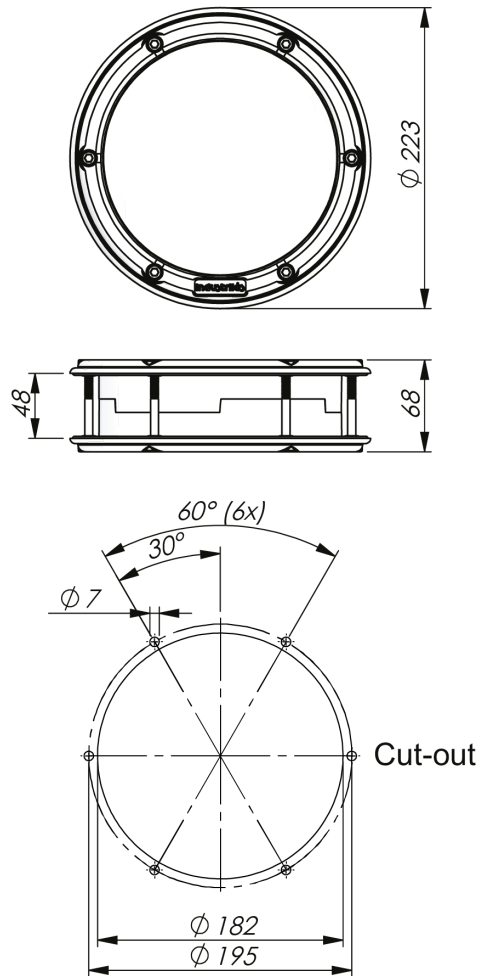

P/N	Door thickness	X in mm
506001-48	48 mm $\pm$ 2 mm	68 mm