

THREE-POINT CAMS STEEL

Three-point cams for use with housings with internal limitation of rotation. Stroke: 20 mm. Supplied with E-clips.

In the drawing, C = housing length, H = outside face to engagement point of cam.

Other lengths and versions available on request.

MATERIAL

Cam: Steel, zinc plated

RELATED PRODUCTS

Rods: 2-540, 2-541, 2-545

Protective cap: 2-480

Other materials: 2-491

Use the Index Code at industrilas.com

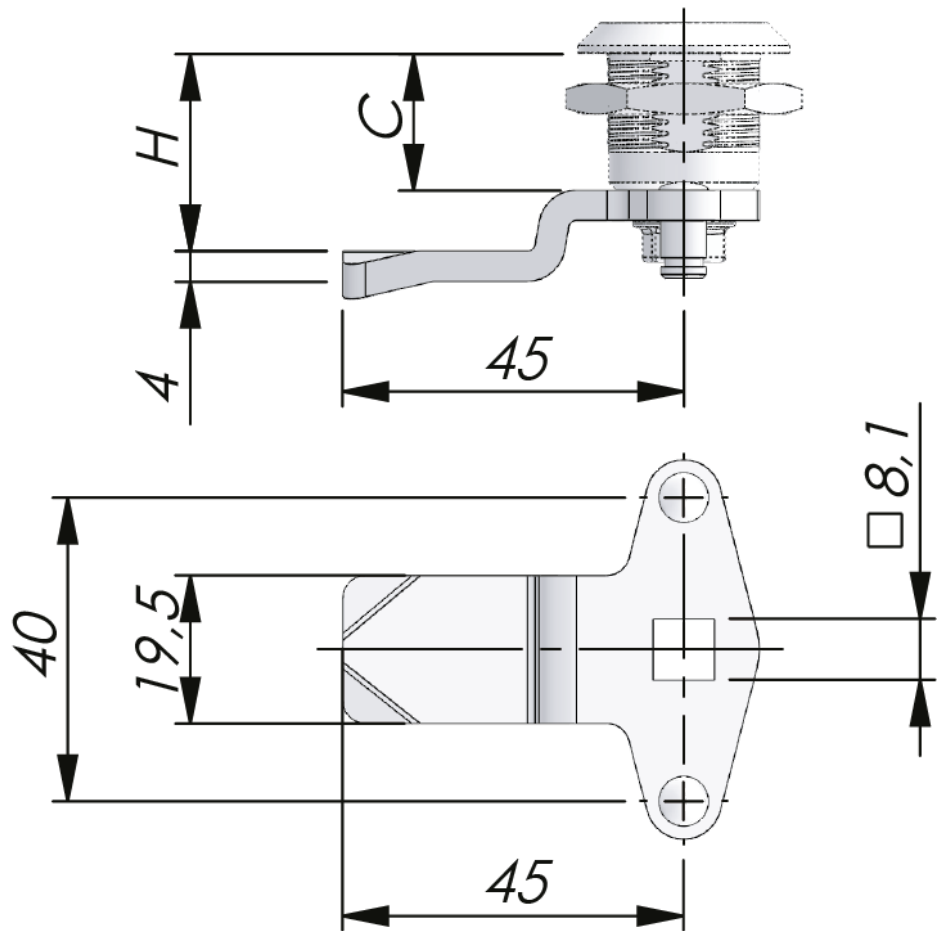

CELATOR.COM.MX

P/N	Description	C=12	C=18	C=30	C=45	C=56
2321S01-U	---	-	4	16	31	42
2321S02-U	---	-	6	18	33	44
2321S03-U	---	2	8	20	35	46
2321S04-U	---	4	10	22	37	48
2321S05-U	---	6	12	24	39	50
2321S07-U	---	8	14	26	41	52
2321S08-U	---	10	16	28	43	54
2321S09-U	Straight cam	12	18	30	45	56
2321S10-U	---	14	20	32	47	58
2321S11-U	---	16	22	34	49	60
2321S12-U	---	18	24	36	51	62
2321S14-U	---	20	26	38	53	64
2321S15-U	---	22	28	40	55	66
2321S16-U	---	24	30	42	57	68
2321S17-U	---	26	32	44	59	70
2321S18-U	---	28	34	46	61	72
2321S20-U	---	30	36	48	63	74
2321S21-U	---	32	38	50	65	76
2321S22-U	---	34	40	52	67	78
2321S23-U	---	36	42	54	69	80
2321S24-U	---	38	44	56	71	82
2321S27-U	---	44	50	62	77	88
2321S28-U	---	42	48	60	75	86
2321S29-U	---	40	46	58	73	84

H in mm when housing length C=12, 18, 30, 45 or 56 mm.