

INTELLICLAMP 3D 40X80 MM



3D-Intelliclamp for connection of sections or units. The 3D-Intelliclamp will align separate units in X-, Y- and Z-axis as the through-bolt is tightened. Provides a solid connection with perfect alignment of surfaces. Mounting with rivets or screws. Each 3D-Intelliclamp consists of two interlocking halves, through-bolt and nut.



MATERIAL

Interlocking parts: Zinc die cast, black texture powder coated or zinc plated
Through-bolt and nut (M8): Steel, zinc plated

RELATED PRODUCTS

Similar products: 5-402, 5-401
 Use the Index Code at industrilas.com

TECHNICAL INFORMATION

Tighten the through-bolt using a 6 mm hexagon key (Allen key). Screws, bolts or rivets for mounting are not included

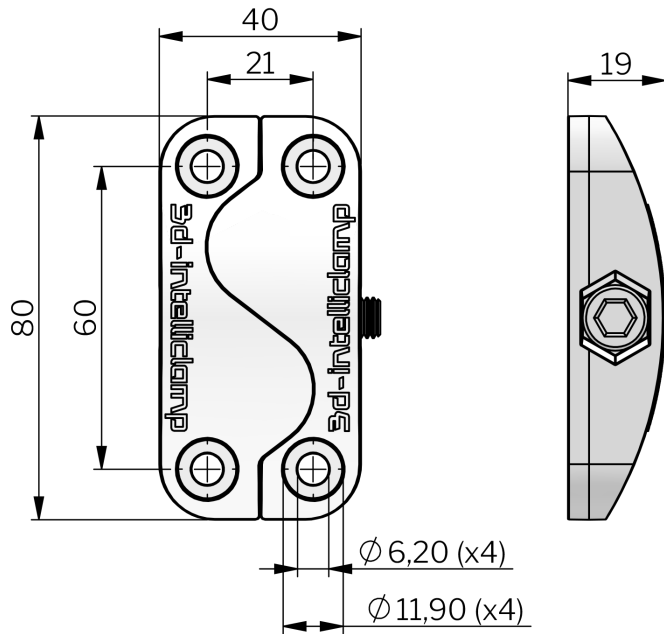

P/N	Description	Surface treatment
275015-01	3D-Intelliclamp™ 40 x 80 mm	Black texture powder coated
275015-02	3D-Intelliclamp™ 40 x 80 mm	Zinc plated