

INSPECTION WINDOW SQUARE

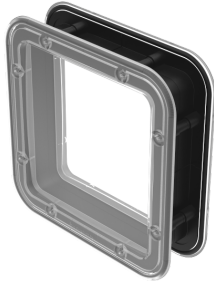

Square inspection window in transparent, impact-resistant polycarbonate. Intended for HVAC-applications using insulated or double-skinned doors. The window is equipped with an integrated gasket and is suitable for units with positive or negative pressure. Simple mounting by using eight self-tapping stainless screws from one side only. No fastening hardware on the inside ensure perfect thermal breakage. Mounting screws are included.

Sealed against dust and water according IP66.



MATERIAL

- Screw:** Stainless steel 304
- Sealing:** Foam rubber, EPDM
- Spacer:** Black ABS
- Window:** Polycarbonate V0, UV stabilized

RELATED PRODUCTS

- Similar products:** 5-255
- Accessories:** 5-425
- Use the Index Code at industrilas.com

TECHNICAL INFORMATION

Sealed according to L1 DIN EN 1886.
 Inspection windows for other door thicknesses upon request. Customer logo may be included upon request. Door thickness tolerance: ± 2 mm.
 Window material (Polycarbonate/Macrolone 6555) is approved according to VDI 6022, sheet 1 (04/2006) for microbiologically inert material. UL94V resistant.

Standards: IP66, VDI 6022

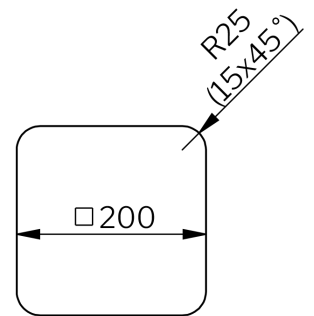
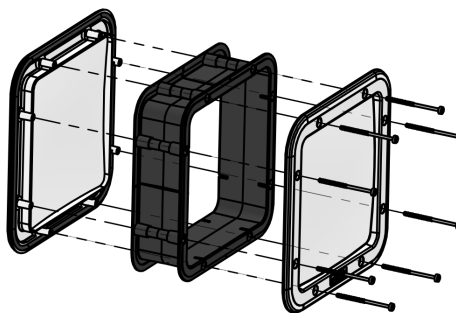
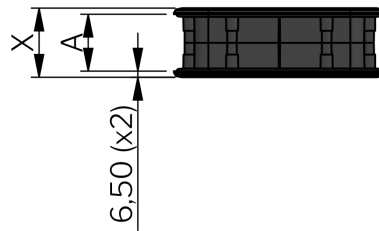
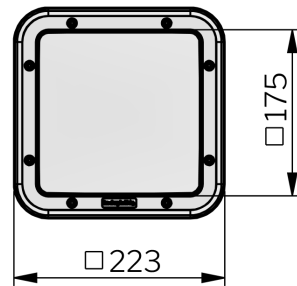

P/N	Description	A [mm]	X (mm)
506002-40	223 x 223 mm	40	53
506002-50	223 x 223 mm	50	63
506002-60	223 x 223 mm	60	73

