

VISION OUTSIDE HEAVY-DUTY



Vision Heavy-duty is designed for low- and medium voltage applications with risk for electric arc explosions. The Vision Heavy-duty latching system makes it possible to operate heavy-duty locking points along several sides of a door. Place the heavy-duty locking points according to your needs and add Vision guide points to simplify closing the door. Add a re-directional corner for each additional door side you want the locking points on.

When using the latching system to prevent accidents during an electric arc, the whole application must be tested and approved by appropriate authorities to receive a certificate for use.

Rods will be designed for each application. Please contact Industrilas for more information.



MATERIAL

Cog wheel: Stainless steel 304

Control mechanism: Glass fibre reinforced polyamide (PA6GF30)

Roller: Brass

Guide block: Zinc, zinc plated, polyamide (PA6GF30)

Latch point: Zinc die cast, zinc plated

Rod: Steel, zinc plated or stainless steel 316

RELATED PRODUCTS

Handles: 1-004.04, 1-004.05, 1-006.50, 1-002.01, 1-002.03, 1-002.02, 1-002.08, 1-006.01, 1-006.03, 1-007, 1-005.10, 6-010
Use the Index Code at industrilas.com

TECHNICAL INFORMATION

Rods will be designed for each application. Please contact Industrilas. The door part of the heavy-duty latching point is welded onto the door. The assembly is powder-coated after welding and finally the PA6 guide bushings are snapped in position.

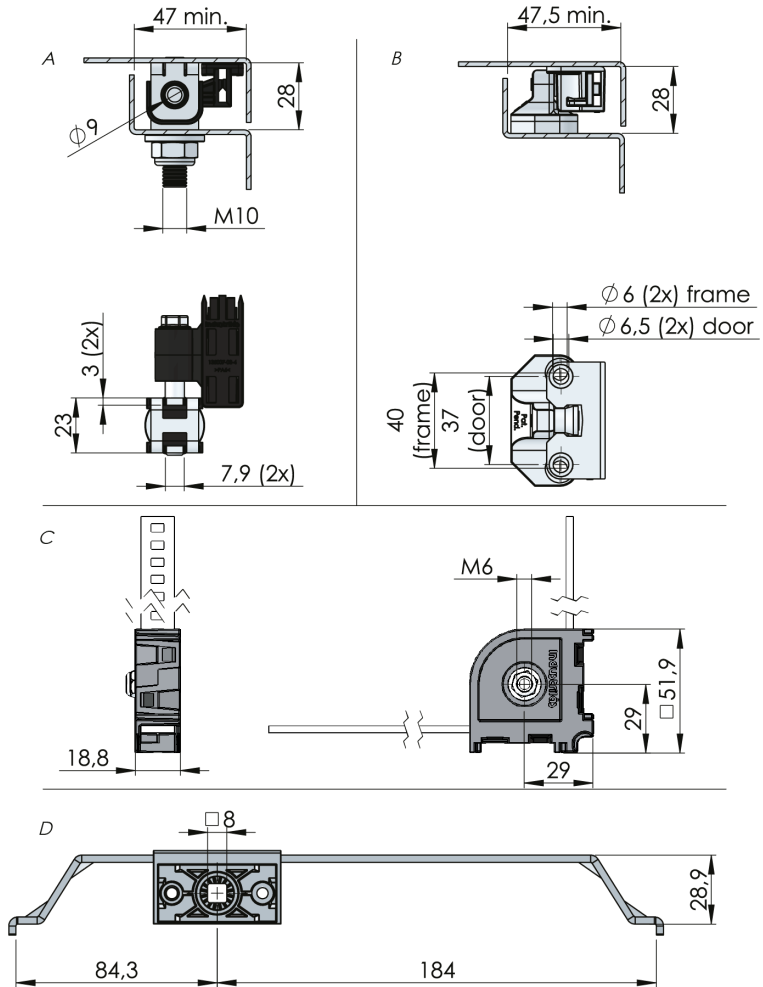

P/N	Description	Drawing
131105	Control mechanism	D
131108	Latching point - frame part and door part included (both for bolt-on mounting)	B
132107-06	Latching point - bolt-on frame part with weld-on door part	A
135001	Corner control mechanism	C

